

Affinity Collection

# J51L

60" X 36" X 21"

END DRAIN



JETTAVHIRL  
HYDROTHERAPY

# JETTA

# PORTER

60" X 36" X 21" - RECTANGLE (1 PERSON)

## FEATURES

- 12 seamless InvisiJets including:
  - 2 jets on each end
  - 4 body jets on each side
- 2 B.P.H. pump – 9 Amps
- Suitable for drop-in or undermount applications
- High gloss/high impact acrylic
- Totally insulated with polyurethane foam
- Passive warm air induction system
- Gravity flow draining for sanitary bathing
- Anti-microbial flex piping
- Pre-leveled lip
- Slip resistant bottom
- Linear drain
- Sound absorption
- 10 year limited factory warranty



JettaWarm is a surface heating system secured beneath the acrylic in a blanket of insulation to provide gentle warmth on the back rest of your tub before your bath begins.

Activates in minutes, bathers can relax from the moment they enter the tub. Soaker tubs have full backrest coverage, while a whirlpool or combo has a system designed to wrap around the hydrotherapy features and warm the acrylic where you need it.

JETTACORP.COM



Jetta guarantees that the water temperature in our insulated whirlpool baths will stay within 2 degrees of its original fill temperature for 30 minutes of use without an inline heater.

## OPTIONS AVAILABLE

- Mood or LED light
- Spa pillows
- 6" acrylic grab bars
- JettaWARM Heated Backrest

## COLORS AVAILABLE

**Standard Color:** White

**Decorator Colors\*:** Biscuit

\*Requires additional lead time

## RECOMMENDED OPERATING GALLONS

**Minimum:** 41

**Maximum:** 82

\*Minimum operating gallon capacity required for system operation



# J51L

# Affinity Collection PORTER

JETTA WHIRL HYDROTHERAPY | 60" X 36" X 21" | END DRAIN

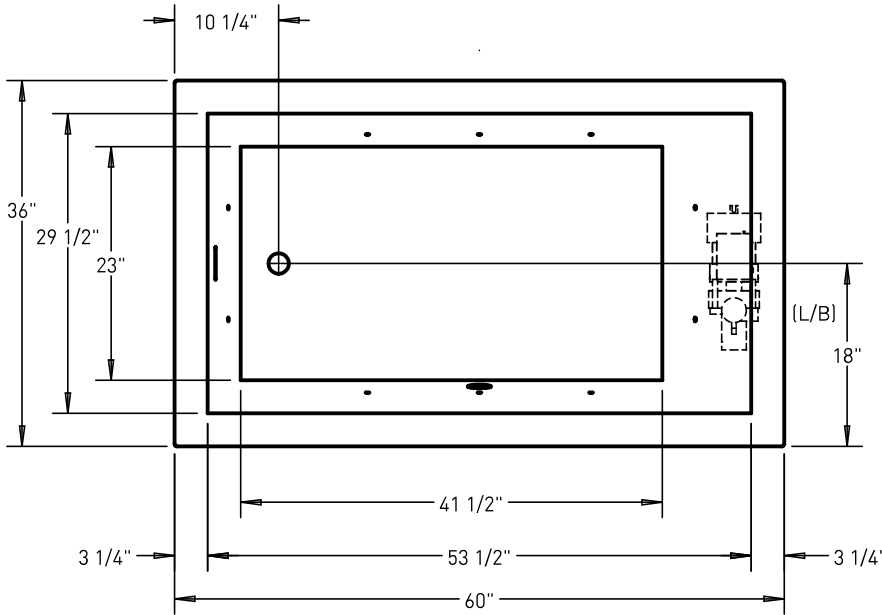

Note: optional pump/blower positions available.  
R/B for right side drain, L/B for left side drain



## INSTALLATION: MEASURE TUB BEFORE BUILDING TUB DECK.

For best results, Jetta Corporation recommends 1"-3" of mortar bedding under the tub base for maximum support. Drawing shows manufacturer's standard pump location(s). Contact Jetta for details. Dimensional variance on drawings may be +/- 1/2 inch and are subject to change without notice.

JETTACORP.COM

## ELECTRICAL SPECIFICATIONS

Required Electrical Service 110/115 Volts  
Standard Whirlpool 20 amp GFI  
Each pump must be protected by a dedicated GFI breaker (refer to local codes).

## CODES/STANDARDS APPLICABLE

Specific model meets or exceeds the requirements for the following standards: ANSI, ASME.

## SUGGESTED PUMP ACCESS PANEL

Suggested access size 20" x 12"  
Actual size may vary depending on distance of access to pump location.

## DROP-IN CUT OUT DIMENSIONS

Subtract 1" from length and width dimensions  
Actual cut out dimension 59" x 35"

SHIPPING WEIGHT 150 lbs

\*L/B pump positions are standard.  
Custom pump locations available upon request.



© 2020 Jetta Corporation. All rights reserved. Specifications are subject to change without notice.  
REV 09/2020

# TECHNICAL SPECIFICATIONS