



RM-10-HC

Glass Door Merchandiser with Swing Door



RM-10-HC
04/22/22
Item # 13546

W x D x H
25" x 22.5" x 54.75"



Item #: _____
 Project: _____
 Qty: _____
 AIA#: _____

Features

- ▶ Curved vertical corners with silver aluminum exterior provide enhanced product display
- ▶ Forced air evaporator for quick temperature pull down
- ▶ Energy saving hot gas loop on front edge of cabinet helps prevent condensation

- Listed under NSF/ANSI Standard 7 for the storage and/or display of packaged or bottled products.
- Large glass door is energy efficient Low-E multi pane glass
- Door is mounted on heavy duty hinges with self-closing mechanism
- Energy efficient vertical LED interior lights illuminate products on display
- Silver painted aluminum exterior with NSF approved white steel interior and stainless steel floor
- Environmentally friendly CFC-Free Polyurethane insulation with cyclopentane blowing agent.
- (3) white epoxy coated shelves per section with product stops are standard
- Stackable (two units high) to conserve warehouse floor space
- Stainless steel shelf clips adjustable in 1/2" increments on anodized aluminum supports
- Refrigerant flow is controlled with a capillary tube
- 8 Foot cord and plug
- 2 inch leveling legs standard

Capacity:
20 oz. bottles: 168
12 oz. bottles: 288

Container Qty: 54



Dimensions / Capacity

	One Section RM-10-HC
Interior Storage Capacity (CF)	10 ft ³
Overall Width x Depth	25" x 22.5"
Height	54.75"
Depth with Door Open	46.7"
Adjustable Shelves	3
Shelf Dimensions (W x D)	21" x 17.5"
Crated Shipping Weight	230 lbs.
Crated Width x Depth x Height	30" x 28" x 60"

Electrical / Refrigeration

	One Section RM-10-HC
Voltage	115/60/1
HACR Breaker	15.0 Amps
Electrical Connection (NEMA)	5-15P Ⓢ
Voltage Range	104-126
Ambient Temp. Range	60° to 86°F
Control Setpoint Range	32° to 39°F
Amperage	1.8
Energy Consumption (kWh/day) @ASHRAE	1.1
Approx. Nominal Compress. BTU/HR (HP)	841(1/5HP)
Refrigerant / Charge Amount (oz)	R290 / (1.8oz)

Options

- Organizer shelf (HS-5446)
- Price tag holder (HS-5290)
- Epoxy Shelf (HS-5447)
- 4" Casters (HS-5288)
- 2.25" Casters (HS-5037)

Warranty

3 Year - Parts and Labor on entire machine.
 5 Year - Parts on Compressor
 Valid in United States, Canada, Puerto Rico and U.S. Territories. Contact factory for warranty in other countries.



RM-10-HC

Glass Door Merchandiser with Swing Door



RM-10-HC
04/22/22
Item # 13546

FRONT VIEW

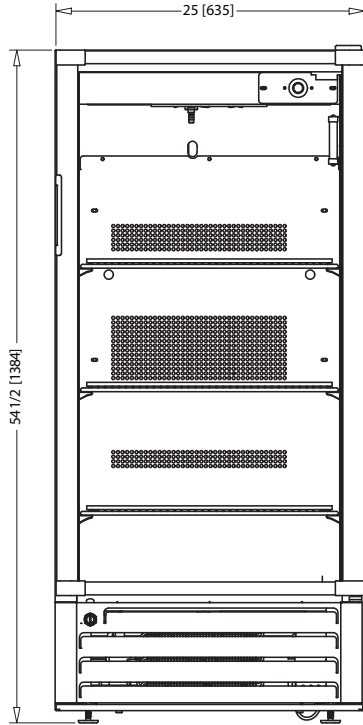

SIDE VIEW

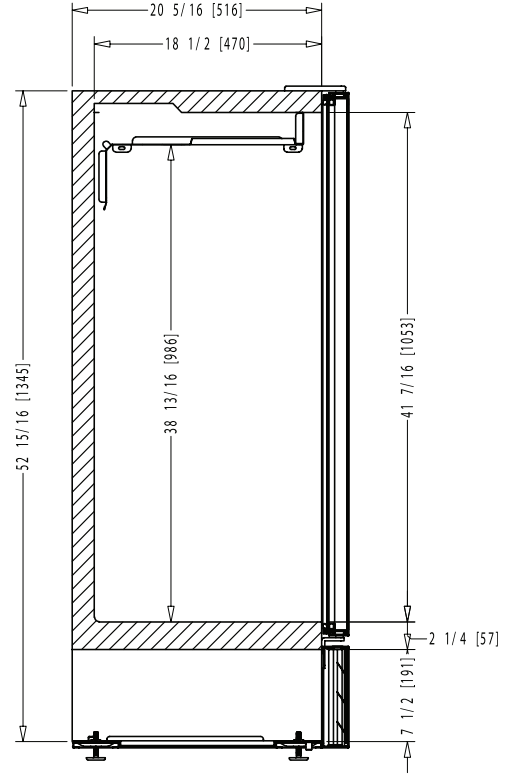

PLAN VIEW

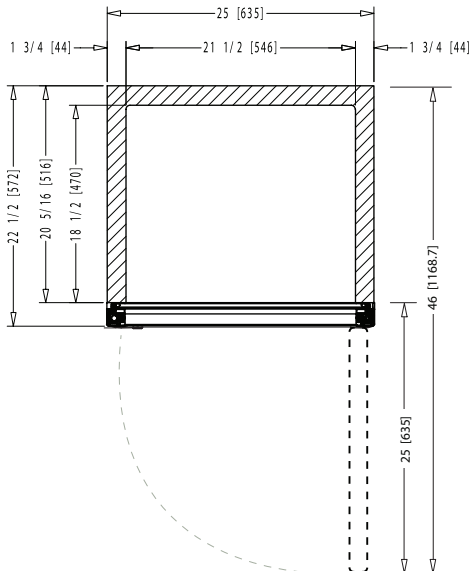

HEADER DIMS

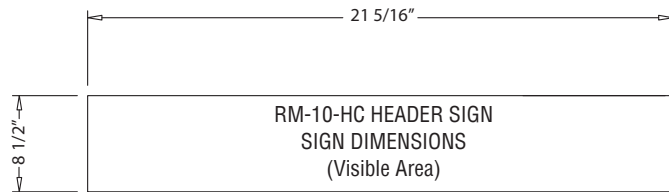

Graphic Requirements:

- 360 dpi resolution. Scale 1=1
- Colors for CMYK process
- Image with 1/4" of excess by side
- Graphics must be saved in photoshop (with layers)
- (or your sign company file type requirements)
- Include a full color print out

Material Requirements:

- 3M exterior grade UV resistant vinyl adhesive

Note: Texts and important parts of the image should be within the visible area. The visible area is illustrated by dotted lines when it applies.