









- 
AMBIENT LIGHT
- 
LED LIGHT
- 
HUSH SYSTEM
- 
DIM LIGHT
- 
TOP PERFORMANCE
- 
CRS
CFM REDUCTION

ELICA'S EXCLUSIVE PLUS FEATURES

Designed to be suspended above a kitchen island, Cingoli takes flight with graceful 36" or 42" arched glass wings, which allow natural light to illuminate the surface below. The expansive glass wings are complemented by reflective stainless steel. The beauty of Cingoli is combined with features such as a powerful 600 CFM blower, dishwasher-safe stainless steel microhole filter and glass touch controls that deliver convenience and safety.

Designed for standard ducted installation, Cingoli can also be installed as a recirculating system using the Recirculating Kit, available as an accessory.

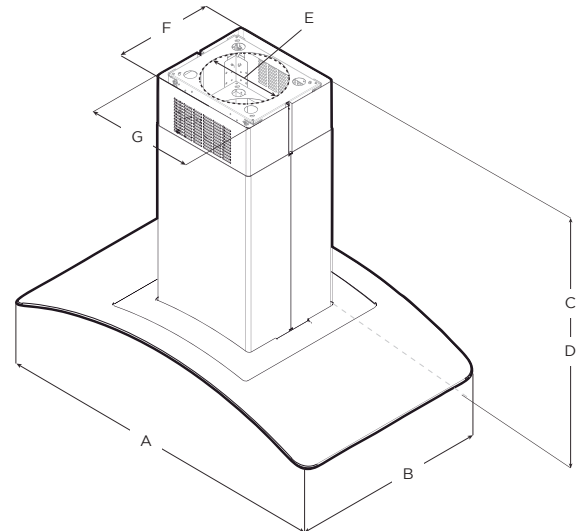

- 
≥24"
- 
≥30"

MOUNTING HEIGHT RANGE

	Models	
	ECN636S3	ECN642S3
A	36" (91.44 cm)	42" (106 cm)
B	25 ¹ / ₄ " (64 cm)	
C*	Max: 49 ¹³ / ₃₂ " (125.3 cm) Min: 29 ¹³ / ₃₂ " (74.5 cm)	
D**	Max: 44 ²¹ / ₆₄ " (112.4 cm) Min: 29 ¹³ / ₃₂ " (74.5 cm)	
E	6" (15.24 cm)	
F	12" (30.5 cm)	
G	13 ⁵ / ₆₄ " (33.2 cm)	

* Ductless (Recirculating) version
** Ducted version

SPECIFICATIONS



	36" UNIT	42" UNIT
Model:	ECN636S3	ECN642S3
Dimensions:	36"W x 25 3/16"D x 1 15/16"H	42"W x 25 3/16"D x 1 15/16"H
Blower Type(internal):	430 CFM, 4-Speed Internal	
Blower Performance:		
Speed 1	160 CFM	
Speed 2	280 CFM	
Speed 3	470 CFM	
Speed 4	600 CFM	
Noise (sones): Working Speed	Min: 2.36, Max: 6	
Finish:	Stainless Steel + Black Glass	
Controls:	Touch Control 3S+ Booster	
Illumination:	2 Premium LED Dimmable Lights	
Filter Type:	2 Dishwasher-Safe, Stainless Steel Baffle Slot Filters	
Installation Type:	Ducted (Recirculating Kit sold separately)	
Duct Transition:	Round 6"/150cms	
Electrical:	120 Volts, 60 Hertz, 394 Watts, 3.27 Amps	
KITS:		
Optional Recirculating Kit	KIT02665	
Optional Long Chimney Extension	KIT0100317	

PLUS FEATURES



AMBIENT LIGHT - Elica studies on hood lighting leaves no stone unturned. Here we have thought about products not only able to light the cooktop, but the entire kitchen space. And so the hood is transformed: from a kitchen appliance to a true lighting element. Considering the design of Elica hoods, it is not hard to imagine how this option is quite unique, and represents one extraordinary point of strength for us.



LED LIGHT - LED lighting is undoubtedly the smartest solution in terms of energy saving. Expected life time of over 20.000 hours, represents the most remarkable advantage of LED light bulbs.



HUSH SYSTEM - An exclusive sound deadening technology that effectively reduces sound levels up to 35%, compared to typical range hoods.



DIM-LIGHT - The Dimmer allows you to adjust the brightness of the light as you wish. With Elica, lighting is customized in a discreet, personal and practical way, in order to contribute in creating the perfect kitchen atmosphere.



TOP PERFORMANCE - Excellent performance for models equipped with this plus. High fume capturing capacity with an average aspiration range of 600 CFM's. with low noise levels, 1.2 - 1.7 sones at working speed.



CFM REDUCTION - CFM Reduction System (CRS), is an exclusive feature to Elica hoods, which enables the user to reduce directly in the glass touch control the maximum blower CFM, to meet local code requirements.